

Accessories

'L' & 'Z' Brackets with Cover Plates for Armlock® 261 & 262

A T S



Function

Adjustable 'L' Bracket with Cover Plate: Suits typical outward opening door applications where there is not sufficient space to fit the magnet to the head of the door frame.

'L' & 'Z' Brackets with Cover Plates: For conversion of Armlock® 260 Series magnets to inward opening door applications, the 'L' & 'Z' bracket kit consists of a standard 'L' bracket and two separate fully-adjustable cover plates which form the 'Z' bracket.

Rim Armature Housing: For situations where it is preferable not to drill a hole right through the door for the armature bolt (such as fire doors), the rim housing enables the armature plate to be mounted on the surface of the door.

Note: Suitable for new installations only, **not** as a direct replacement for standard 'L' & 'Z' brackets.

Specifications

Adjustable 'L' Bracket with Cover Plate:

Dimensions: 31mm x 253mm x 50mm.

Material: Aluminium.

'L' & 'Z' Brackets with Cover Plates:

Dimensions: See page 29.

Material: Aluminium.

Rim Armature Housing:

Dimensions: 55mm x 175mm x 15mm.

Material: Aluminium.

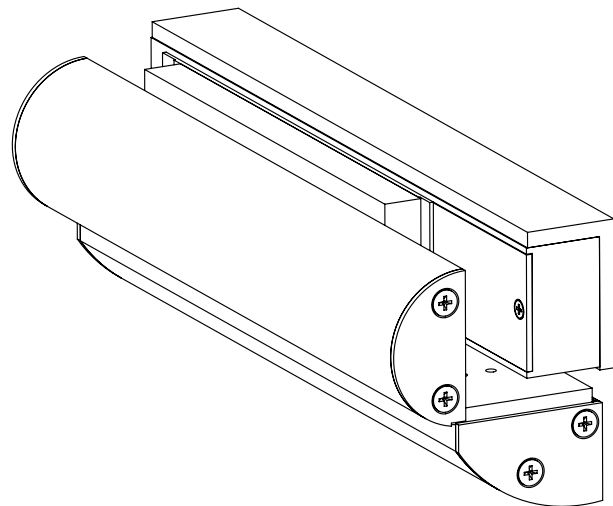

Dimensions

Adjustable 'Z' Brackets with Cover Plates (included in 261-801 kit).

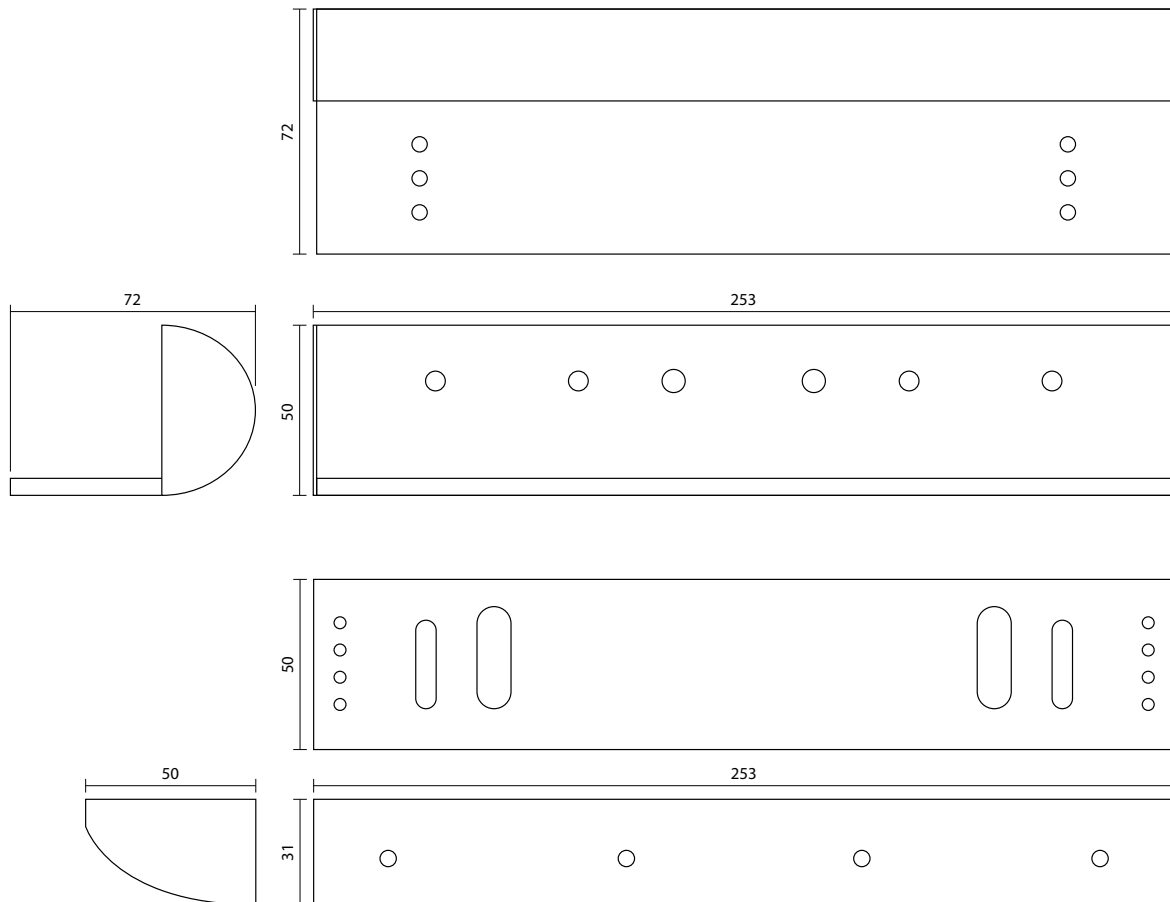

Standard 'L' Bracket (included in 261-801 kit).

Adjustable 'L' Bracket with Cover Plates available separately (see ordering codes).

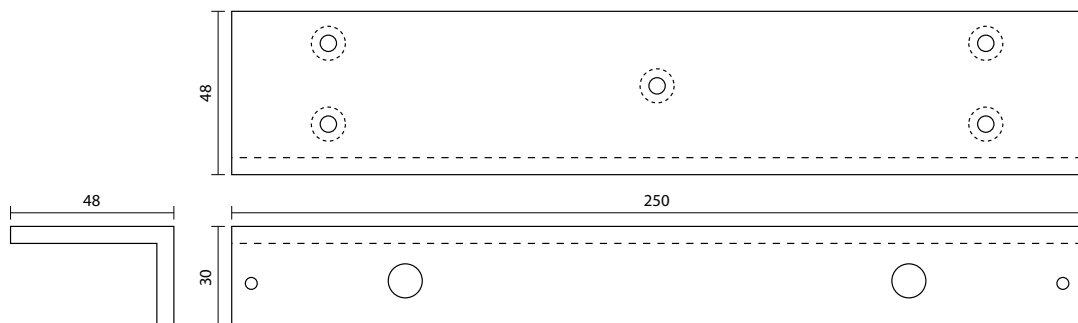

Ordering Codes

- 261-701 Adjustable 'L' bracket only, with cover plate, SAA finish
- 261-801 'L' & 'Z' bracket kit with cover plates, SAA finish
- 261-900 Rim armature housing, SAA finish (see page 27 for illustration)

Related Hardware

Armlock® 261 (p24)