

**ELECTRIC STRIKE DIMENSIONS**

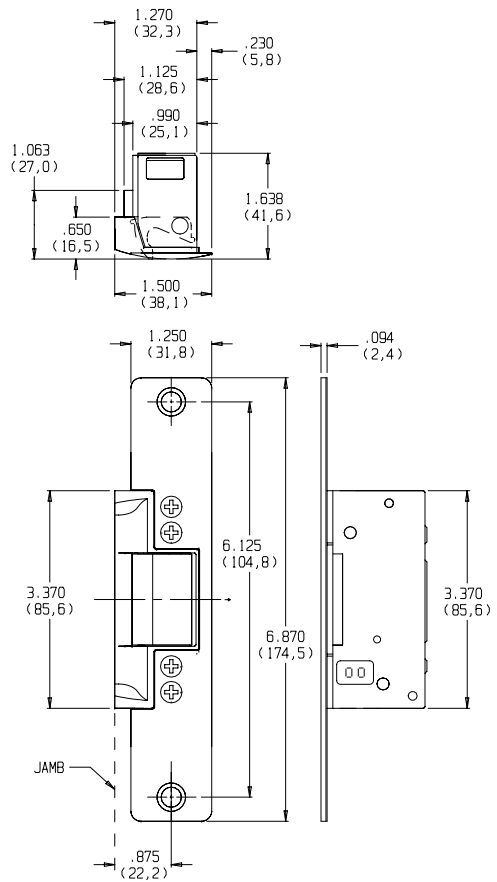

**STILE PREPARATION**

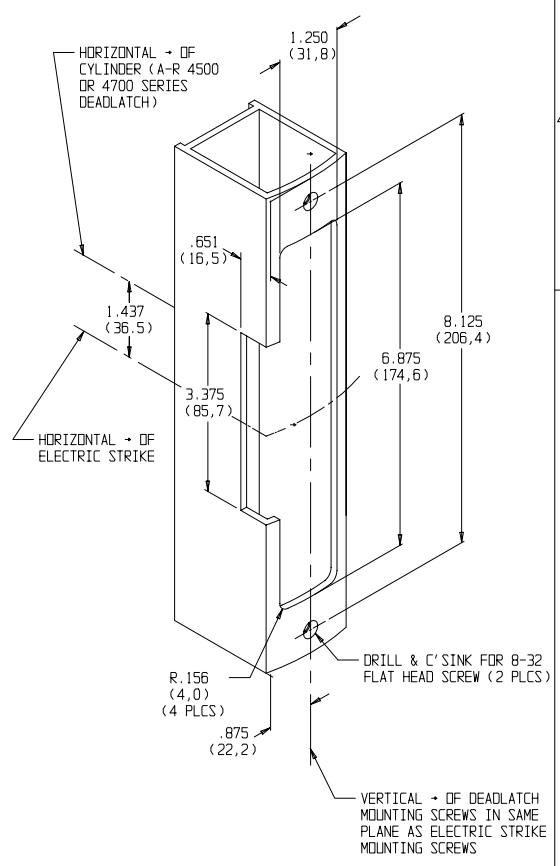

**INSTALLATION INSTRUCTIONS**

1. PREPARE DOOR STILE PER DRAWING.
2. INSTALL MOUNTING CLIPS TO STILE USING 8-32 X 3/8 SCREWS & PRESSED METAL NUTS. LEAVE SCREWS SLIGHTLY LOOSE TO PERMIT EASY ALIGNMENT OF CASE ASSEMBLY & CLIPS.
3. SPACERS ARE PROVIDED TO ASSURE FLUSH FINAL ASSEMBLY OF FACE PLATE & STILE. ADD ONE OR MORE SPACERS BETWEEN STILE & MOUNTING CLIP WHEN FACE PLATE EXTENDS BEYOND THE STILE. WHEN THE FACE PLATE SETS INSIDE THE STILE, SPACERS MUST BE ADDED BETWEEN THE MOUNTING CLIP & THE ELECTRIC STRIKE FACE PLATE. SEE DETAIL "A" TO ATTACH SPACER TO MOUNTING CLIP. REMOVE PROTECTIVE COATING FROM SPACER & PRESS TO DESIRED MOUNTING CLIP SURFACE. MAKE SURE CLEARANCE HOLE IN SPACER ALIGNS WITH HOLE IN MOUNTING CLIP.
4. ATTACH SUBCOVER AND FACE PLATE TO THE CASE ASSEMBLY USING FOUR 8-32 X 1/4 SCREWS.
5. USING WIRE NUTS PROVIDED, CONNECT WIRES COMING FROM THE STRIKE TO THE WIRES COMING FROM THE LOW VOLTAGE SIDE OF THE TRANSFORMER.
6. INSERT ELECTRIC STRIKE INTO STILE AND ATTACH TO THE CLIPS USING TWO #12 COMBINATION SCREWS.
7. SECURE 8-32 SCREWS HOLDING MOUNTING CLIPS TO STILE.

STATIC STRENGTH	DYNAMIC STRENGTH	ENDURANCE
1500 lbs.	70-foot-pound-force	250,000 cycles

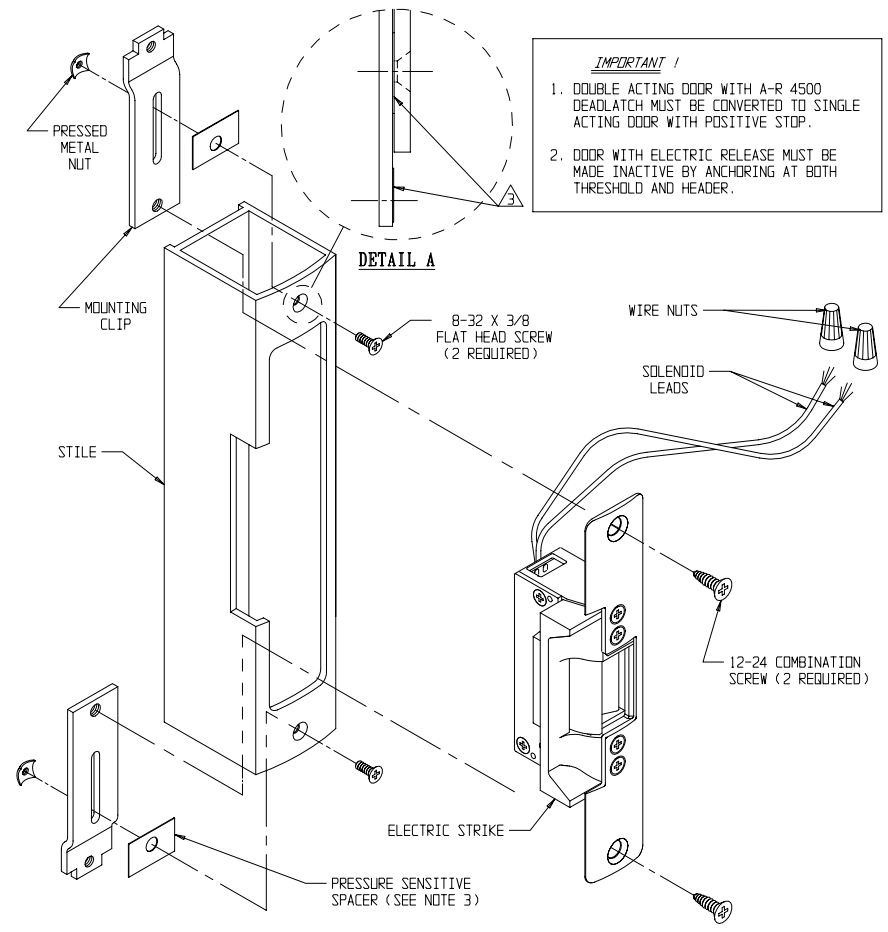

**IMPORTANT !**

1. DOUBLE ACTING DOOR WITH A-R 4500 DEADLATCH MUST BE CONVERTED TO SINGLE ACTING DOOR WITH POSITIVE STOP.
2. DOOR WITH ELECTRIC RELEASE MUST BE MADE INACTIVE BY ANCHORING AT BOTH THRESHOLD AND HEADER.

ADAMS RITE MANUFACTURING COMPANY  
CITY OF INDUSTRY, CA 91749

7131 ELECTRIC STRIKE  
FOR ALUMINUM STILE WITH  
A-R 4500/4700 DEADLATCHES

REF. TEMPLATE NO. : 52070-0

PART NO. : 80-0180-361  
REV. : 0  
ECN : 9685  
DATE : 11-03-97

**Notes:**

**Fail-Secure Operation -** Unlocks when energized. If power fails the strike remains in a locked condition.

**Fail-Safe Operation -** Locks when energized. Used in applications requiring automatic unlocking in case of power failure.

**Available Voltages:** 12V AC Intermittent duty, 12V AC/DC Continuous duty, 16V AC Intermittent duty, 16V AC/DC Continuous duty, 24V AC Intermittent duty, 24V AC/DC Continuous duty.

**Warning !**

AC Intermittent duty solenoids are designed to be energized 30 seconds at a time. Energizing for longer periods will damage the solenoid.

AC Continuous duty strikes are supplied with a A/R # 4603 rectifier attached to the solenoid leads. These are silent operation strikes - without the "buzzing" sound. They use a DC solenoid with an externally attached, full-wave bridge rectifier.

**Wiring**

The number of wires will vary depending on features of the strike. The voltage and amperage ratings are marked on all strike labels. The solenoid wires are not polarized.

**Monitoring (Optional)**

Monitored strikes contain two, internally mounted, switches: one is activated by the latch bolt's penetration of the strike and the other indicates that the strike jaw is either locked or unlocked by the solenoid.

All unused leads from monitor switches should be insulated.

- Common contact -Black
- Normally open contact (NO) -White
- Normally closed contact (NC) -Red
- Maximum switching current -7 Amps @ 250 VAC

**Warning !**

Intermittent duty solenoids should not be converted to fail-safe configuration. Fail-safe units use only continuous duty solenoids.

**Solenoid Data**

24 VDC CONT.	WHITE STRIPE ON BLACK	141.6	.170	.170	4.09	4.09
16 VDC CONT.	GREEN STRIPE ON BLACK	61.8	.222	.222	3.05	3.05
12 VDC CONT.	RED STRIPE ON BLACK	34.6	.332	.332	3.81	3.81
24 VAC INT.			.744	.431	19.15	6.43
16 VAC INT.	BLUE STRIPE ON BLACK	16.3	1.030	.636	17.30	6.60
12 VAC INT.	YELLOW STRIPE ON BLACK	8.8	1.420	.813	17.74	5.82
DESCRIPTION	WIRE COLOR	COIL RESISTANCE (OHMS ±5%)	PEAK INSTANTANEOUS CURRENT (AMPS)	CONTINUOUS OR HOLD CURRENT (AMPS)	PEAK INSTANTANEOUS POWER (WATTS)	CONTINUOUS OR HOLD POWER (WATTS)

Control Switch (N.O.)  
(ex. Pushbutton, keypad, Card Reader)  
**DRY CONTACTS!**

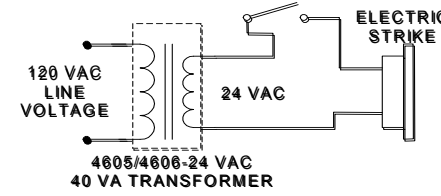

**TYPICAL ELECTRIC STRIKE WIRING DIAGRAM  
INTERMITTENT DUTY FAIL-SECURE 24 VAC**

Control Switch (N.O.)  
(ex. Pushbutton, keypad, Card Reader)  
**DRY CONTACTS!**

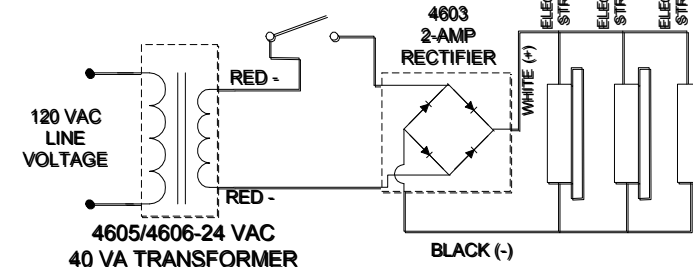

**TYPICAL ELECTRIC STRIKE WIRING DIAGRAM  
INTERMITTENT/CONTINUOUS DUTY 24 VDC**

**WIRE CODING (MONITORED VERSION)**

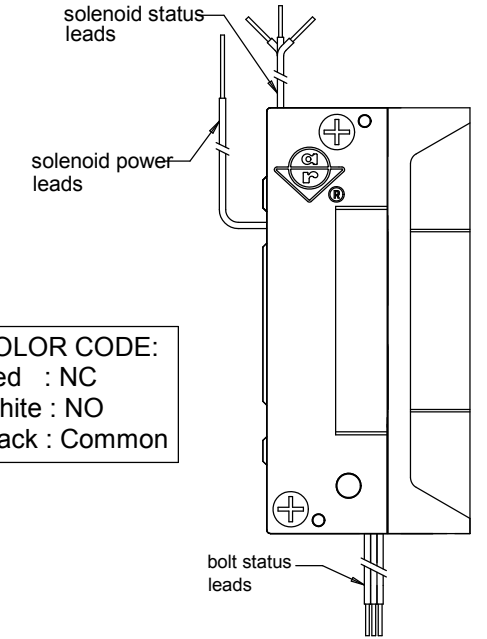

**COLOR CODE:**  
Red : NC  
White : NO  
Black : Common

**FIELD REVERSIBLE (FAIL-SECURE)**

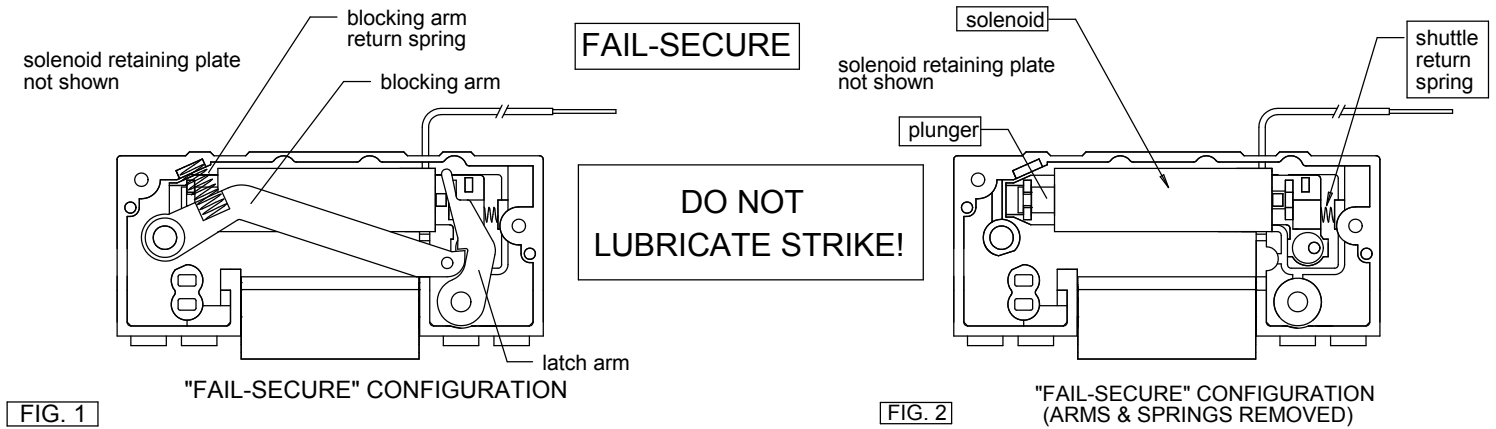

**FIELD REVERSIBLE (FAIL-SAFE)**

